

# MOBILE PHONE OPERATED SPY ROBO

## Introduction

Normally wireless controlled robots used 4 channel RF control circuits which have the limited working range up to 100 or 200 meters in open area & have limited control. Use of mobile phones for robotic control can overcome these limitations. It provides the advantages of precise control & large working area & long range, no RF interference with other controllers & use up to 12 separate controls. Spy robo are the versatile robo which performs various functions such as surveillance, collecting audio video datas & other tasks for defence & commando operations. Various loadings such as human motion detection, ultrasonic collision avoiding systems, night vision camera, hypnotic gases, chemical evaquators etc are mounted on a moving platform.

## Working

In this project, the spy robots is controlled by a mobile phone that makes a call to the mobile phone attached to the circuit. During the call if any button is pressed a tone corresponding to the button pressed is heard at the receiver this tone is called Dual Tone Multiple Frequency (DTMF) tone. The robots perceive this DTMF tone from the phone & tone is processed by the microcontroller with the help of DTMF decoder MT 8870. The decoder decodes the DTMF tone into an equivalent binary digits & this binary number is send to the microcontroller. The microcontroller is programmed to generates outputs which control the motor drivers to drive the motors for forward/backward & left/right movements.

# Block Diagram of Mobile Phone Operated SPY Robo

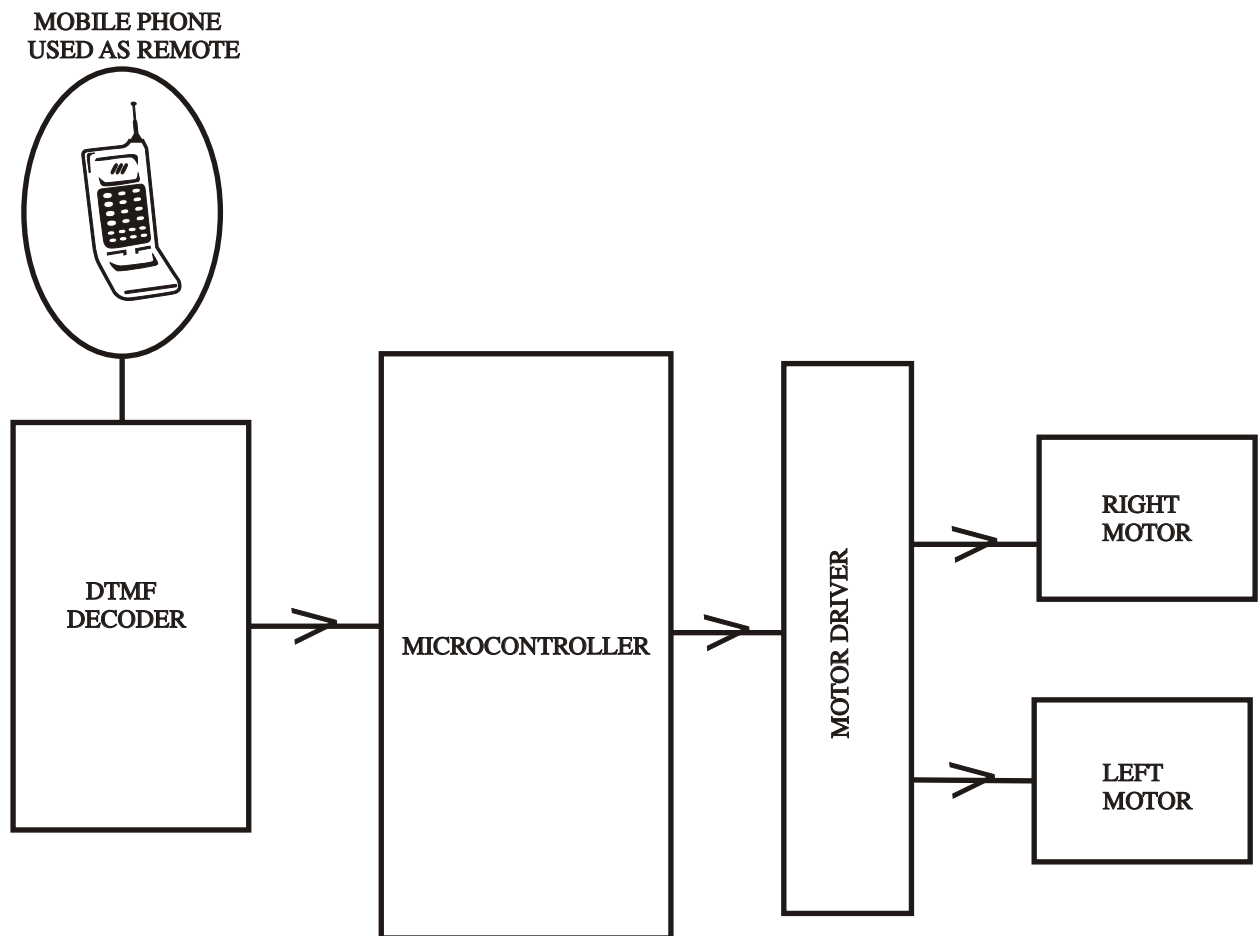

## Components :

- 1) MT 8870 DTMF decoder.
- 2) Atmega 16 AVR microcontroller.
- 3) L293D motor driver.
- 4) Resistors
- 5) Capacitors
- 6) Miscellaneous components
- 7) Battery 6 V

## Reference :

- 1) [www.dkdynamics.com](http://www.dkdynamics.com)
- 2) Embedded Systems by BJT